

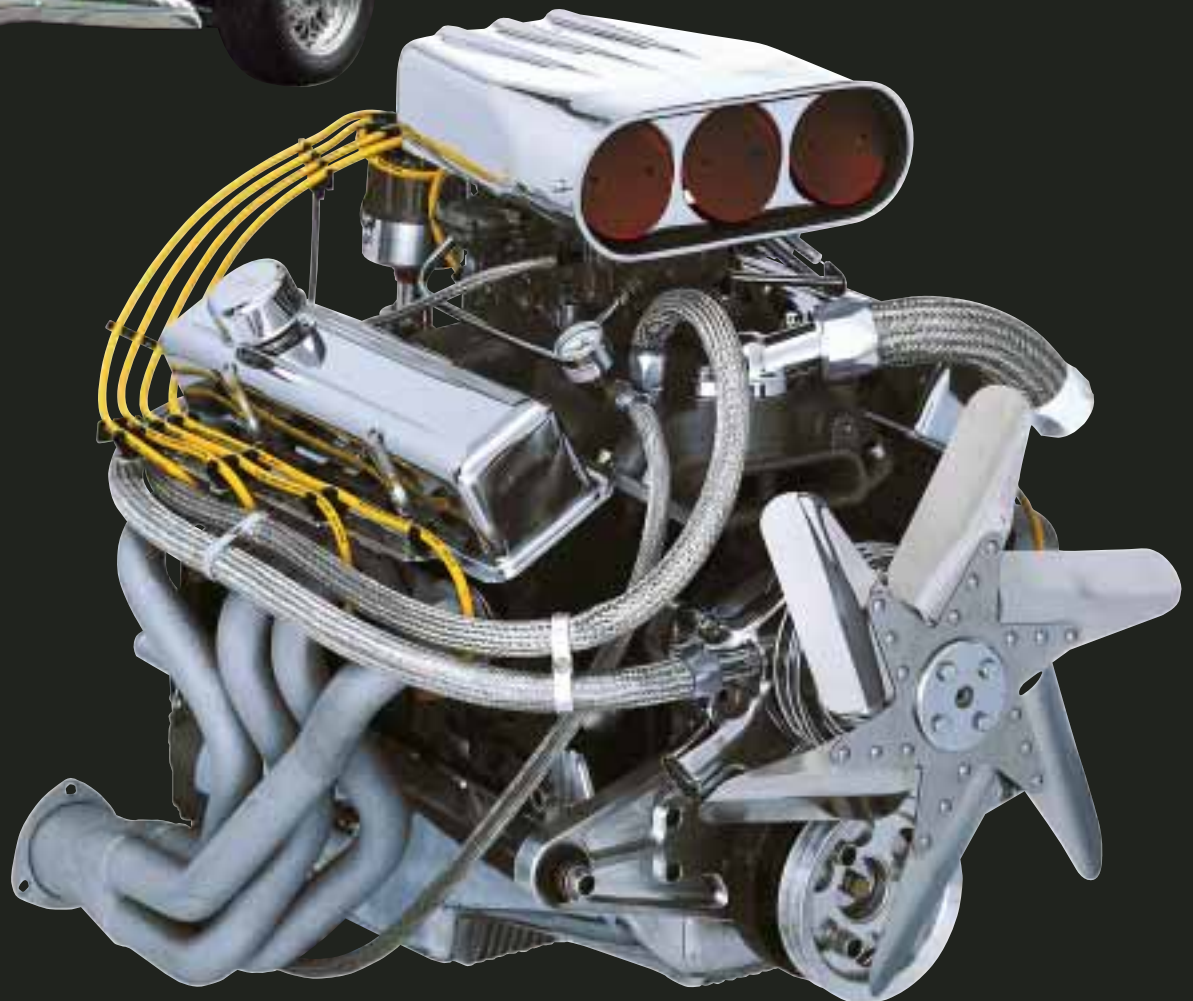

RODWARE™
THE RODDER'S HARDWARE



WHAT'S NEW!



SHADOW SERIES FITTINGS24-26



RADIATOR HOSE14



**SOUND AND
HEAT INSULATION15-16**



**IGNITION AND
DISTRIBUTORS17-22**



**AFTERBURNER
SWITCHABLE COIL21**



6A & 6AL IGNITION BOXES21



**HURST
COLLECTIBLES31**

ACCESSORIES AND INTERIOR PRODUCTS28

AIR CLEANERS AND SCOOPS2-3

CHROME-PLATED FASTENERS12-13

COLLECTABLES AND APPAREL31-32

ENGINE COMPONENTS AND ACCESSORIES4-11

EXTERIOR PRODUCTS29-30

FUEL SYSTEM COMPONENTS23-26

IGNITION SYSTEMS AND ACCESSORIES17-22

RADIATOR AND HEATER HOSES14

SHIFTERS AND ACCESSORIES27

SOUND AND HEAT INSULATION15-16

COMPLETE INFORMATION

There are about 200 products shown in this catalog. Overall, there are over 12,000 products available from the Mr. Gasket Performance Group Companies. For COMPLETE product and application information, visit your local performance specialist or visit www.mrgasket.com and download all of the Mr. Gasket Performance Group catalogs.

6650B



THE ORIGINAL STREET SCOOP

These cast aluminum Street Scoops are fully machined and available polished or in a classic black wrinkle finish. They feature large diameter red anodized butterflies that operate off the carburetor linkage. Designed to bolt on to most stock and tunnel ram manifolds and superchargers that use two inline 4-bbl. carburetors with 5-1/8" diameter necks and 7-3/4" to 9-1/4" center line spacing. Also fits single 4-bbl. carburetors.

	Polished	Black
Fits most two 4-bbl. carb. set ups66506650B
Fits most single 4-bbl. carb. set ups66516651B

6658



STREET SCOOP II

Here's the sequel to The Original Street Scoop. For single four-barrel carburetors, a shorter version, only 14-1/2" long, a full 5-1/2" shorter than The Original Street Scoop! Ideal for V6 and small V8 engines.

	Polished	Black
Fits 5-1/8" diameter carb neck66586658B

5232B



5233

HILBORN STYLE SCOOPS

These authentically styled air scoops are made from highly polished aluminum castings and fit single or dual carb applications using carburetors with 5-1/8" diameter necks. The dual carb scoop features an adjustable base to fit carburetor's with 7-5/8" to 9-1/4" center line spacing.

Description	Length	Width	Height	Polished	Black
Single Four Barrel	...13-5/8"	...9-3/4"	...5-9/16"	...5232	...5232B
Dual Four Barrel	...20"	...9-3/4"	...5-7/8"	...5233	...5233B

6477



LOUVERED AIR CLEANERS

These louvered air cleaners are made from heavy gauge steel and are chrome-plated and polished to a high luster. Includes stud and wing nut. The 14" diameter air cleaner features thirteen groups of five louvers each. The low profile design is 2-1/2" high and fits carburetors with 5-1/8" diameter necks. The 6" diameter air cleaner is ideal for use on most tri-power carburetor set-ups. It includes a mounting stud and wing nut. Fits 2-5/16", 2-5/8" and 3" diameter carb necks.

14" Louvered Air Cleaner6477
6" Louvered Air Cleaner6475

4338



LOW RIDER AIR CLEANERS

These 14-inch air cleaners are designed to fit vehicles where the hood clearance is minimal. These air cleaners feature a chrome-plated top with a flame-retardant, high CFM filter for maximum efficiency. All applications come with PCV fittings and necessary hardware for easy installation. Height is 2-1/4" inches.

2-bbl. with 3" carb. neck4338
2-, 3- and 4-bbl. with 51/8" dia. carb. neck, ideal for Corvettes	...4339

AIR CLEANERS & SCOOPS



CHROME-PLATED ALUMINUM AIR CLEANERS

These air cleaners are available in three eye-catching shapes: round, triangle, and oval, and in three different designs: wild flames, smooth ball milled, or classic bright polish. Fits 5-1/8" diameter carburetor necks.

12" x 2" Oval-Plain Top9155G
12" x 2" Oval-Ball Milled Top9156G
12" x 2" Oval-Flamed9157G
14" x 3" Round-Plain Top9160G
14" x 3" Round-Ball Milled Top9161G
14" x 3" Round- Flamed Top9162G



BILLET ALUMINUM AIR CLEANER NUTS

Made from billet aluminum with knurled sides for easy hand tightening. Measures 3/4" high x 1" diameter with 1/4-20 threads.

Clear Aluminum5326
Blue Anodized5327
Red Anodized5328



CUSTOM AIR CLEANER NUTS

The custom accessory for a performance engine! The spin nut is chrome-plated for lasting beauty and enhances any air cleaner. Fits all 1/4 - 20 and 5/16-18 studs.

Small Spin Nut9862
Large Spin9863
Tri-Bar Spin Nut9868
Wing Style Nut, 1/4-20 only6398



UNIVERSAL AIR CLEANER STUD

This stud allows you to gain more filter power by using a 5" high element or stacking two stock filters. Kit contains stud, 5/16" stud adapter and a silver finish wing nut.

Universal Air Cleaner Stud6399
----------------------------------	-------





6854

ALUMINUM VALVE COVERS

These aluminum valve covers are precision die cast for light weight and a perfect fit. Beautifully polished to a high luster, they are sure to enhance the appearance of any engine compartment. They feature an extended sealing lip to positively locate and secure the gasket and stop it from moving under pressure to eliminate oil leaks. The valve cover tops are a full .125" thick so they can be custom milled or engraved. These valve covers are available with plain or ball-milled tops and include a 1 1/4" diameter breather hole, except where noted. Packaged two per set.

Chevy Small Block 283-400

<u>YEARS</u>	<u>DESCRIPTION</u>	<u>HEIGHT</u>	<u>PART NO.</u>
58-85	Plain top, w/baffle	Short	.6850
58-85	Plain top, w/baffle	Tall	.6854
58-86	Flamed top	Short	.6866G
58-86	Flamed top	Tall	.6867G
87-97	Flamed top	Short	.6868G



6867G



6868G

CHROME VALVE COVER WING BOLTS

Chrome-plated for beauty and durability, wing bolts make valve cover removal fast and easy. They are precision engineered and feature extra long threads to allow for the additional thickness of Mr. Gasket's re-usable valve cover gasket and custom valve covers. Four per kit.

Standard "Y" Top

1/4"-20 x 5/8" thread for stock valve covers - Chevrolet V-89824

1/4"-20 x 1" thread for custom stock covers - V-8 cast covers,
Chrysler Wedge engines - stock Corvette 1964 and up -
stock Ford V8, 260-289-302 cu. in.9826

5/16"-18 x 1" thread for cast covers-Ford V-8,
352-390-427 cu. in.-Pontiac V-8, 1955 and later9829

Deluxe Top

1/4"-20 x 5/8" for stamped covers9827

1/4"-20 x 1" for cast covers9828



9824

9828

CUSTOM VALVE COVER NUTS

Machined from 1/2" O.D. billet aluminum with a knurled top and 3/16" socket head for easy installation. 2" tall and packaged four per set, complete with 1/4"-20 x 1" studs.

Clear Aluminum	.5335
Blue Anodized	.5336
Red Anodized	.5337



5337

CHROME-PLATED VALVE COVER ACORN NUTS

Machined from solid steel, these chrome-plated nuts are 1-3/8" tall with 1/4"-20 thread. Kit includes eight acorn nuts with studs.

Valve Cove Acorn Nuts	.6304
-----------------------	-------



6304

CHROME-PLATED ALUMINUM PUSH-IN BREATHERS

Aluminum breathers add life to the world of engine ventilation. Available in ball milled, flamed, or chrome aluminum finishes.

Push-In Breather		PCV Push-In Breather	
Plain	.9115G	Plain	.9118G
Ball Milled	.9116G	Ball Milled	.9119G
Flamed	.9117G	Flamed	.9120G



9120G

9116G

BAFFLED BREATHER GROMMETS

Designed to virtually eliminate oil breather blow-by, a common problem encountered on non-baffled valve covers with push-on breathers. They are made to fit most valve covers that use 1.22" O.D. x 1" I.D. grommets. These grommets will not work with stud girdles.

Baffled Breather Grommets, 2 per set	.5425
--------------------------------------	-------



5425

ALUMINUM PCV VALVES

Hi-tech machined aluminum PCV valve fits valve covers with 1" I.D. grommets and will accept a 3/8" I.D. PCV hose.

Clear Aluminum	.5553
Polished Aluminum	.9150G



9150G



9105G

CHROME-PLATED ALUMINUM TIMING COVER

Chrome-plated aluminum timing chain cover includes gaskets, seal and bolts. For use with OEM style timing chain only. Double roller type chains or gear drives require checking for adequate clearance.

Fits Chevrolet small block 1955-879105G



5415

FINNED ALUMINUM OIL PAN

Fully polished finned aluminum oil pan is precision die-cast and machined for a perfect fit. Pan is complete with drain plug and mounting bolts. 4-quart capacity.

Fits Chevy Small Block, 265-350, 1955-79,
(Except 62-67 Chevy II), Corvette 1955-655415



9140G

CHROME-PLATED ALUMINUM WATER NECKS

These O-ring style water necks feature a swivel top that allows you to place your coolant hose where you want it to be, not just in one fixed position. They are available with a 90° bend, a 45° bend, or straight up and include mounting hardware. For Chevrolet applications only.

Early Water Neck 55-65 – Straight9140G
Late Water Neck 67-75 – 45° Swivel9141G
Late Water Neck 90° Swivel9142G



9130G

COOLANT OVERFLOW TANKS

Made from Stainless Steel, these coolant tanks look great, resist stains and perform even better. available in 2" diameter and multiple lengths, will fit just about anywhere inside engine compartment. Includes mounting hardware.

Stainless Steel 2" x 13" Overflow Tank9130G
Stainless Steel 2" x 17" Overflow Tank9131G
Stainless Steel 2" x 19" Overflow Tank9132G



9131G



9132G



9125G

ALUMINUM FUEL PUMP BLOCK-OFF PLATES

These polished aluminum fuel pump block off plates are ball milled for the finest appearance and are complete with gasket.

Chevy 265-400 Engine9125G
Chevy 396-454 Engine & Most GM V-6 / V-89126G

9126G

ENGINE COMPONENTS AND ACCESSORIES



BILLET STYLE ALUMINUM PULLEYS

These machined aluminum pulleys are designed to fit most Chevy small block engines. All pulleys are heat-treated and have an attractive satin finish. Also available is a matching water pump nose cover, which conceals the end of the pump shaft for that hi-tech look, and an aluminum alternator pulley for GM applications. All pulleys and nose covers are sold separately. For Small Block Chevrolet applications only.

DESCRIPTION	STYLE	YEARS	PART NO.
Water Pump Pulley, Short			
Single Groove	SWP	'55 to '685310
Double Groove	SWP	'55 to '685311
Crankshaft Pulley, Short			
Single Groove	SWP	'55 to '685312
Double Groove	SWP	'55 to '685313
Water Pump Pulley, Long			
Single Groove	LWP	'69 to '855314
Double Groove	LWP	'76 to '855315*
Crankshaft Pulley, Long			
Single Groove	LWP	'69 to '855316
Double Groove	LWP	'69 to '855317
Triple Groove	LWP	'69 to '855318
Water Pump Pulley Nose5319
Alternator Single Groove Pulley with Nose Piece5320



SWP-Short Water Pump, LWP-Long Water Pump *Will not fit 69 to 75.
Use #5321 Bolt Kit if not using a conventional fan.

PERFORMANCE POWER PULLEYS

These underdrive pulleys are engineered for high performance and daily street driving. Dynamometer tests have shown an increase of up to 18 streetable horsepower with the installation of a Mr. Gasket Performance Power Pulley Kit. All pulleys are CNC machined from aircraft quality material and are computer designed and tested to assure that electrical and cooling systems function properly. Recommended replacement belt numbers are included in instructions where necessary.

DESCRIPTION	PART NO.
GM TRUCK 1988-00 With 262 V6, 305-350 V8 Eng., (W/External Alternator Fan) Crankshaft and alternator pulley4757
FORD MUSTANG 1994-95 With 5.0L Eng., Crankshaft, water pump and alternator pulley4761
FORD MUSTANG, CAPRI AND PICK-UP TRUCK 1979-93 With 5.0L Eng., Crankshaft, water pump and alternator pulley4759





7014

7012

ALUMINUM WATER PUMPS

Available in aluminum or chrome-plated finishes, these high volume water pumps feature a superior design that flows up to 45% more fluid for improved cooling. The chrome pumps are meticulously hand polished and triple chrome-plated. They are brand new units that feature large heavy-duty bearings and an 8-hole universal hub with a 3/4" shaft. For Small Block Chevrolet applications only.

DESCRIPTION	STYLE	FINISH	PART NO.
1955-72.	Short Style	Chrome	7011
1955-72.	Short Style	Aluminum	7014
1969-76.	Long Style	Chrome	7012
1969-76.	Long Style	Aluminum	7013



5122

CHROME-PLATED ALTERNATORS

Quality chrome-plated and remanufactured to exceed OEM specifications for maximum dependability. All units are tested and output rated to 80 amps.

GM 73-83 (Non-Metric) with Internal Regulator, Single Groove Pulley5122
GM 66-72 with External Regulator, Single Groove Pulley5123
Ford 61-85 Single Groove Pulley5124



3698

FLUIDZAP™

FluidZap is a highly absorbent disposable pad that can contain any automotive liquid including gasoline, transmission fluid, motor oil, brake fluid, anti-freeze, power steering fluid, water and more.

It is perfect for use under cars, trucks, motorcycles and lawn equipment – or anywhere that something may leak and spill causing a dirty or unsafe condition. It is also ideal for use on workbenches – especially when working on oily or greasy projects like transmissions or small engine repairs. FluidZap pads are so absorbent that each pad can contain up to 1/2 quart of oil!

Single 17" x 23" pad3698
Box of 150 17" x 23" pads3699
Roll of 133 pads3700

Conserve our Natural resources. Dispose of used pads according to your Federal, State or Local disposal laws.

BILLET ALUMINUM ALTERNATOR FAN AND PULLEY

This lightweight billet aluminum alternator fan and pulley replaces the stock stamped steel fan and pulley and gives the alternator that dynamic hi-tech look. Fits most GM-Delco, and Ford alternators.

Fan5602G
Pulley5599



LOW MOUNT ALTERNATOR BRACKET

Designed to mount the alternator on the lower front drivers side of a Small Block Chevy. Made from heavy gauge steel to eliminate flex, the brackets are highly polished then chrome plated. Kit must be used with the short water pump for proper pulley alignment and is complete with hardware and detailed instruction sheet.

Low Mount Alternator Bracket Kit5179



STAINLESS STEEL BATTERY TRAY

This polished stainless steel battery tray resists rust and corrosion and will accommodate batteries up to 7-1/4" wide x 13-1/8" long. Includes stainless steel H-style hold-down top bracket.

Stainless Steel Battery Tray5282



CHROME-PLATED EXHAUST MANIFOLD COVERS

Fabricated from heavy gauge steel and chrome-plated, these covers feature a louvered top for faster heat dissipation and are made to cover the stock OEM exhaust manifolds on small block Chevrolet engines without A/C.

Chrome-Plated Exhaust Manifold Covers5117



STAINLESS STEEL MOTOR MOUNT COVERS

Made from pre-polished, heavy gauge stainless steel, these covers will fit over most Chevrolet V-8 motor mounts.

Stainless Steel Motor Mount Covers5285



5285

GROMMET SET

This heavy-duty grommet set includes 30 of the most popular grommets as used in automotive sheet metal applications. The grommets feature an extra thick wall section to insulate and protect wires, cables, hoses, etc. from the sharp sheet metal edges. Kit includes six grommets of each size to fit the following hole diameters: 1/2", 5/8" 3/4" 7/8" & 1"

Grommet Set3706



3706

HIGH PERFORMANCE ELECTRIC COOLING FANS

SIMPLY PUT: These fans are the best on the market!

HERE'S WHY: High torque, low amperage draw motor.

The motor rides on Dual Ball Bearings, not on bushings like some others. Reversible Fan Blades engineered to provide maximum air flow. Our fans provide more efficient cooling at low speeds where it is needed most. They also free up more usable horsepower to the rear wheels, and increase fuel economy. Their extremely low profile design makes installation easy even in very limited space. With five sizes to choose from, all being reversible, it makes it easy to find your customers the correct fan for their specific application. Ideal for replacement automotive engine cooling fans where applicable, remote engine oil or automatic transmission oil cooler applications. Perfect for installations where air flow is limited or does not exist in, such as under chassis, rear under-body, and trunk mount cooler installations. Perfect for street rods, recreational or towing vehicles, custom-built kit cars and engine swaps.



DESCRIPTION	CFM	RPM	AMP DRAW	PART NO.
9" Diameter70026005.51984
10" Diameter95026008.31985
12" Diameter1400230010.21986
14" Diameter1800210010.31987
16" Diameter2000190011.41988

ELECTRIC COOLING FAN APPLICATION CHART

ENGINE DISPLACEMENT	W/ AIR CONDITIONING	W/O AIR CONDITIONING
cubic inch	quantity & part no.	quantity & part no.
61-181	1.0-3.0	*(1) 1986 & (1) 1988
182-244	3.1-4.0	*(1) 1986 & (1) 1988
245-460	4.1-7.5	*(1) 1986 & (1) 1988

ELECTRIC FAN ASSEMBLIES OVERALL DIMENSIONS:

ELECTRIC FAN	DEPTH (D)	HEIGHT (H)	WIDTH (W)
9" Diameter 3.20" 10.24" 9.56"
10" Diameter 3.09" 11.28" 10.72"
12" Diameter 3.09" 13.25" 12.60"
14" Diameter 3.40" 14.69" 14.00"
16" Diameter 3.40" 16.56" 16.00"

*NOTE: Air conditioning applications listed above must use 12" diameter fan 1986 as an auxiliary (pusher air flow) cooling fan. Auxiliary fans must be mounted in front of A/C condenser or radiator.

PERFORMANCE GASKETS

For complete gasket application information, refer to the Mr. Gasket catalog or www.mrgasket.com

ULTRA-SEAL® HEAD GASKETS

- Five layer (graphite core/ perforated steel outer layers) composition construction
- Graphite core has excellent thermo-conductivity; transfers heat away from hot spots in head to coolant passages, this prevents gasket burn-out
- Provides excellent stability, compressibility and high temperature endurance
- Will not creep, cold-flow or brinell (indent) aluminum cylinder heads
- For high performance street, drag race and oval track
- Packaged 2 per set

DESCRIPTION	PART NO.
UltraSeal Head Gasket SB CHEV 283-3505800
UltraSeal Head Gasket BB CHEV 396-454 (Gen IV)5802
UltraSeal Head Gasket FORD 302/351W5807

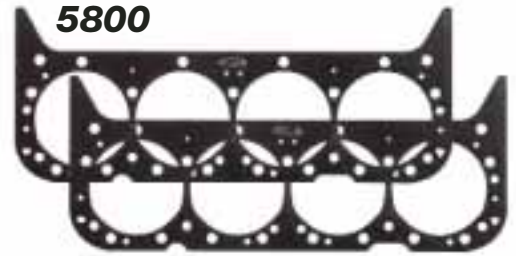

ULTRA-SEAL® INTAKE MANIFOLD GASKETS

The perfect solution to eliminate sealing problems encountered with today's aluminum cylinder heads and intake manifolds.

ENG.	YRS.	DESC.	PORT DIMENSION	PART NO.
265-400 ...	1955-91 ...	1/16" Thick Seals. ...	1.25" x 2.00"5820
			STOCK PORT	



ULTRA-SEAL® EXHAUST & COLLECTOR GASKETS

These premium exhaust gaskets are designed and constructed to improve sealing of exhaust header flanges. Unlike standard exhaust material, ULTRA-SEAL exhaust gaskets incorporate a graphite-impregnated facing and steel expanded metal core that reinforces and increases the tensile strength. This gives the gasket the ability to conform to warped flanges, allowing better sealing capabilities without deteriorating or cracking under excessive heat and pressure of racing engines.

DIA.	BOLT CIRCLE	BOLT HOLE	APPLICATIONS	PART NO.
3"	37/8"	3/8"	Blackjack, Cyclone5971
			Flowtech, Hedman, Hooker, Thorley	



ENG.	YRS.	DESC.	PORT DIMENSION	PART NO.
265-400 ...	ALL	All Stock & Most. ...	1.45" x 1.55"5901
		Small Race Ports		



ULTRA-SEAL® VALVE COVER GASKETS

Made from cork particles blended with special polymers to make our Ultra-20 material. The Ultra-20 material is far superior to standard cork, rubber, or fiber valve cover gaskets because this unique blend causes the Ultra-Seal valve cover gasket to swell to a controlled thickness and not contract like other gaskets do; you will not need to retorque the valve covers. They retain a high-tensile strength to compensate for excessive flange pressures and will not lose compressibility or heat harden under severe racing conditions.

ENG.	YRS.	DESCRIPTION	PART NO.
265-400 SBC	1955-86	3/16" Thick5860





5001

Show quality chrome plated fasteners are available in your choice of Grade 5 hex head, Grade 8 socket head, or Grade 8 twelve point head. The bolt heads of these quality fasteners are individually polished to a high luster, then chrome plated for lasting beauty. Kits come complete (except where noted) with "AN" type washers which have no exposed shoulders past the bolt heads to give a very professional appearance. Ideal for street rods and street machines, or any vehicle requiring show quality chrome.

Complete Engine Bolt Kits

Chevy Small Block - Deluxe kit (Intake, Timing Cover, Oil Pan, Fuel Pump, Water neck, Long Water Pump, Headers)

QTY.	SIZE	HEAD STYLE	PART NO.
24	1/4"-20 x 1/2"	Hex	5001
4	5/16"-18 x 3/4"		
12	3/8"-16 x 3/4"		
13	3/8"-16 x 1"		
2	3/8"-16 x 1-1/4"		
4	3/8"-16 x 2"		
1	3/8"-16 x 2-1/4"		
10	1/4" AN Washers		
14	1/4" Flat Washers		
20	3/8" AN washers		



5003

Chevy Small Block - Engine Bolt Kit

14	3/8"-16 x 1" Intake & water neck bolts		
10	1/4"-20 x 1/2" Timing Cover Bolts		
1	3/8"-16 x 2-1/4" Water neck bolt		
10	1/4" Flat Washers		
14	3/8" AN Washers	Hex	5000
	(Fits early and late water necks)		

Intake Bolt Kits

Chevy Small Block

12	3/8"-16 x 1"	Hex	5002
12	3/8" AN Washers	12 Pt	5003
		Socket	4979



5019

Chevy Big Block

16	3/8"-16 x 1-1/4"	Hex	5004
16	3/8" AN Washers	12 Pt	5005

Ford 289-302-351W

12	5/16"-18 x 2"	Hex	5006
12	5/16" AN Washers		

Valve Cover Bolts

4	1/4"-20 x 3/4"	Hex	5019
4	1/4" AN Washers	Button	5029
		Socket	2507



9822

4	1/4"-20 x 1"	Hex	2501
4	1/4" AN Washers	Socket	2506

4	1/4"-20 x 3-3/8"	Button	9822
---	------------------	--------------	-------------

4 1/4" AN Washers
Fits 86-up Chevrolet Small Blocks

4	5/16"-18 x 3/4"	Hex	2508
4	5/16" AN Washers		

4	5/16"-18 x 1"	Hex	2505
4	5/16" AN Washers		

Acorn Head Valve Cover Nuts

8	1/4"-20 x 1-3/8" Nuts"	Hex	6304
8	1/4"-20 x 7/8" Studs		

CHROME PLATED FASTENERS



QTY.	SIZE	HEAD STYLE	PART NO.
------	------	------------	----------

Timing Cover Bolts

Chevy Small and Big Block
 10 1/4"-20 x 1/2"
 10 1/4" Washers

Hex**5008**
 12 Pt.....**5009**

Oil Pan Bolts

Chevy Small Block
 14 1/4"-20 x 1/2"
 4 5/16"-18 x 3/4"
 14 1/4" Flat Washers
 4 5/16" Flat Washers

Hex**5010**

Rear End Cover Bolts

GM 10 & 12 Bolt
 12 5/16"-18 x 3/4"

Hex**5016**

Water Neck Bolts

Fits Mr. Gasket #2661 Chevy water necks
 1 3/8"-16 x 1"

Hex**5022**

Transmission Pan Bolts

GM TH 350 & 400
 13 5/16"-18 x 3/4"
 13 5/16" AN Washers

Hex**5012**

Header Bolts

12 3/8"-16 x 3/4"
 with small (7/16") head*

Hex***5025**
 12 Pt.....**5027**
 Socket**4985**

Specialty Bolts

Body Bolts, washer faced, CA point
 5 5/16"-18 x 3/4"
 Hood Hinge Bolts, GM 1960 and Up
 8 3/8"-16 x 3/4"
 w/Captive Washer

Hex**5026**
 Hex**5028**

Fuel Pump/Block Off Plate Bolts

Fuel Pump Bolts, Chevy Small and Big Block
 2 3/8"-16 x 1-1/4"
 2 3/8" AN Washers

Hex**4993**

Block Off Plate Bolts

Chevy Small Block
 2 3/8"-16 x 3/4"
 2 1/4"-20 x 1/2"
 2 3/8" AN Washers
 2 1/4" AN Washers

Hex**4987**

Water Pump Bolts

Chevy Small Block with short pump
 1 3/8"-16 x 2-1/2"
 3 3/8"-16 x 1-3/4"
 4 3/8" AN Washers

Hex**4996**

Chevy Small and Big Block with long pump

4 3/8"-16 x 2"
 4 3/8" AN Washer

Hex**4998**
 12 Pt.....**4999**



5008



5010



5026



5025

GFLEX™ FLEXIBLE HOSES

These hoses create a unique look and aid in cooling. They are ideal for engine and radiator swaps. The adapters will accommodate from 1-1/8" to 1-3/4" applications. Hose cuts easily with a common fine tooth hacksaw and cleans easily with mild soap and water. The corrosion-resistant 300-series stainless steel can be shaped in unlimited configurations and will hold its shape once formed. Finishes are heat-resistant flexible high gloss powder coating or triple chrome-plated. Kits include hose, two 3" connectors, two 1-1/8" & two 1-1/2" adapters, four hose clamps and billet covers where noted.

RADIATOR HOSE KITS WITH COLORED END CAPS, 1-3/4" OD

LENGTH	COLOR	PART#
12"	Chrome	.11009C
12"	Black	.11009BL
24"	Chrome	.11010C
24"	Black	.11010BL
36"	Chrome	.11011C
36"	Black	.11011BL
48"	Chrome	.11012C
48"	Black	.11012BL

RADIATOR HOSE KITS WITHOUT END CAPS, 1-3/4" OD

LENGTH	COLOR	PART#
12"	Chrome	.11014C
12"	Black	.11014
24"	Chrome	.11015C
24"	Black	.11015
36"	Chrome	.11016C
36"	Black	.11016
48"	Chrome	.11017C
48"	Black	.11017

HEATER HOSES WITH COLORED END CAPS, 7/8" OD

LENGTH	COLOR	PART#
44"	Chrome	.11013C
44"	Black	.11013BL

HEATER HOSE KITS WITHOUT END CAPS, 7/8" OD

LENGTH	COLOR	PART#
44"	Chrome	.11018C
44"	Black	.11018

Hoses also available in Blue, Green, Red or Yellow. See GSport catalog or www.gsport-online.com for complete product listing.



TITAN-LITE™ SOUND DAMPING MATERIAL

Although extremely light-weight, Titan-Lite is a giant among dampening materials. It provides twice the dampening capability, and is 40% lighter than any of our competitors asphaltic product. Its aggressive adhesive withstands water, fuel, most solvents and temperatures in excess of 250° F, and it stretches up to 40% for 100% bonding to irregular surfaces.

Sample applications include: interior panels to cure annoying squeaks and buzzes, exterior moldings, license plate frames and mounting surfaces, under carpets and upholstery, speaker installations and subwoofer enclosures and under headliners. The possibilities are endless.

Titan-Lite™ Sound Damping Material11027
Includes .075" thick, 12"x32" roll



NEO-FOAM INSULATOR™ SOUND DAMPING MATERIAL

Effective anti-rattle, cushioning gasket material. 1/8" thick nitrile neoprene composite foam with simple peel and stick design. It's water resistant, aggressive adhesive withstands temperatures in excess of 250° F with no unpleasant odors.

Sample applications include: interior panels to cure annoying squeaks and buzzes, exterior moldings, license plate frames and mounting surfaces, under carpets and upholstery, speaker installations and subwoofer enclosures and under headliners. The possibilities are endless.

Neo-Foam Insulator™ Sound Damping Material11029
Includes four .125" thick 10"x10" black sheets



G-SPRAY™ SPRAY-ON SOUND DAMPING MATERIAL

G-Spray is a vibration-dampening compound engineered specifically for spray applications. This product should not be confused with common rubberized undercoating. G-Spray visco-elastic spray contains a significant mineral load; it will convert vibration energy into low level heat, providing twice the dampening characteristics of other asphalt material. G-Spray also contains a corrosion inhibitor.

Use on hard to reach or difficult contours exist. Inside doors, kick panels, trunk wheelwells subwoofer enclosures, body panels, marine hulls, and machinery enclosures. Works great on primed or coated metal, fiberglass, plastic and wood. The possibilities are endless.

G-Spray™ Sound Damping Material Spray11030
Coverage: 4.5 Sq.Ft. / 4180m sq. per 20 oz. can





6322

HEADER WRAP

Increases horsepower and reduces under-hood temperatures. This material withstands 1200°F continuous and 2000°F peak. Will wrap one typical small block header and fastens with Inferno-ties

- 1"wide x 50' x 1/16" thick6321
- 2"wide x 50' x 1/16" thick6322

6321



6323

HEAT REFLECTIVE TAPE

This self-adhesive backed tape is perfect to shield heat away from wires, lines, and cables. It withstands 1000°F radiant, 500°F direct.

- 1-1/2"wide x 15'6323



THERMAL SLEEVING

Provides heat protection for wires, lines and cables in a variety of colors. Withstands 1200°F continuous, 2000°F peak temperatures. Adjustable inside diameter from 1/4" to 7/16", 25' roll.

COLOR	PART NO.	COLOR	PART NO.
Blue	6326B	Red	6326R
Black	6326K	Purple	6326P
Silver	6326S	Yellow	6326Y

6327



6328

STAINLESS STEEL TIES

Used to secure header wrap or other high temperature materials. Made from 304 stainless steel and impervious to under-hood temperatures.

- 8" long for diameters up to 2", 8/kit6327
- 14" long for diameters up to 4", 4/kit6328

6333



INFERNO SHIELD CLOTH

Inferno Cloth reduces interior heat by reflecting over 90% of radiant heat. It is extremely flexible making it ideal for use under carpets. It withstands 500°F direct, 1100°F radiant heat.

- 36" X 40" Cloth6333

IGNITION SYSTEMS & ACCESSORIES



DIGITAL FUEL INJECTION SYSTEMS FOR SMALL BLOCK CHEVY AND FORD ENGINES

Introducing the Pro-Ram Single Plane Small Block Multi-Port Spark/Fuel Management. The new system is available with a cast 750 CFM throttle body, single plane intake manifold, and 30#/hr injectors for engines producing up to 500HP**. For engines producing over 500HP, the system is available with 36#/hr injectors and a billet 1200 CFM throttle body. The manifold, produces excellent power from 2000 RPM to 7000 RPM, has optimized runners for precise air delivery and correct fuel distribution. The system includes intake manifold, throttle body, injectors, ECM, fuel pump, wiring harness, and all components necessary for installation.

** Small block Ford applications include 24 #/hr injectors and is ideal for engines producing up to 400HP. 30#/hr injectors are included with the 1200cfm kit and provides excellent power from 2800 RPM to 7000 RPM. Custom orders available upon request.

Chevy SB Pro-Ram 750cfm77141
Chevy SB Pro-Ram 1200cfm77143
Ford SB Pro-Ram 750cfm w/TFI ignition77145
Ford SB Pro-Ram 1200cfm w/TFI ignition77148



77143



77148

ACCEL 5MM SPARK PLUG WIRES

A radical departure from anything ever offered! Think bigger is better? Think again. With half the diameter of today's standard wires, they are extremely flexible and offer extreme space and weight savings. With the performance of 150 ohms per foot Ferro-Spiral wound alloy conductor, these wires deliver maximum energy to the spark plug and provide superior performance. Available in four colors: blue, red, black and yellow - in universal 8-cylinder wire sets.

COLOR	PART NO.	COLOR	PART NO.
Blue 7541B	Red7541R
Black 7541K	Yellow7541Y



ACCEL 8.8mm 300+ RACE WIRE

The oversized 8mm wire features a double silicone construction rated at over 600°F and 60KV. The high gloss black silicone wire jacket not only looks great, but resists heat extremes, petrochemicals, ozone and moisture better than so-called blended materials for greater durability and longer life. The high-density, high-temperature silicone insulation provides greater dielectric strength and eliminates arcing and the effects of corona better than the typical OE style rubber materials. The all-Kevlar stranded inner core and fiberglass braiding adds greater pull strength and terminal retention. The stainless steel and brass terminals provide unsurpassed electrical conductivity and excellent corrosion resistance compared to terminals made of common or plated metals.

8.8mm 300+, Universal, vari-angle spark plug boots7040
8.8mm 300+, Universal, 90 degree spark plug boots7041
300+ 115 Degree Angled Spark Plug Boot7005
Ford 1977-98 V8, 255, 302, 351, 460 CID engines		



7041

Shown with optional Pro-Sleeve





IGNITION SYSTEMS & ACCESSORIES

ACCEL SuperStock WIRES

Our SuperStock Wire is designed to upgrade an OE ignition system for high spark delivery levels for street-driven applications. The 450°F-rated silicone jacket is extruded over a tightly woven, rugged fiberglass braid which is applied over a high dielectric strength EPDM (Ethylene Propylene Diene Monomer) inner insulation for ignition wire performance that exceeds SAE specifications.

UNIVERSAL SETS

- 7mm Wire Set, copper core with straight spark plug boots3008
- 8mm Wire Set, copper core with straight spark plug boots4038
- 8mm Wire Set, copper core with 90 degree spark plug boots4039
- 8mm Graphite Wire Set, straight spark plug boots4040
- 8mm Graphite Wire Set, straight spark plug boots (blue)4040B
- 8mm Graphite Wire Set, 90 degree spark plug boots4041
- 8mm Graphite Wire Set, 90 degree spark plug boots (blue)4041B

CUSTOM SETS

- 8mm Graphite Wire Set4042
- GMC/Chevrolet, All 1955-74 262-400 CID engs. with points-style dist. cap, wires routed under exhaust manifold or headers



4038B

59107

PERFORMANCE REPLACEMENT DISTRIBUTORS

ACCEL Performance Replacement Distributors are the perfect choice for your daily driver or street machine. Using all new components, these distributors feature high performance ACCEL electronics, all new components, centerless ground shaft, and a high dielectric strength cap & balanced rotor for trouble-free performance. Other features include a male tower distributor cap with brass cap and rotor contacts and steel distributor gear. Direct plug-in replacement with factory type connectors for plug and play easy installation. Legal for installation in all 50 states. C.A.R.B. approval pending.

- GM HEI Distributor w/vacuum Advance,59107
- Fits All Chevrolet V8 Engines (except 348, 409) w/HEI, standard deck height

Also now available with blue, black or red colored caps.

- Blue59107BLU
- Black59107BLK
- Red59107RED



IGNITION SYSTEMS & ACCESSORIES



52 SERIES DISTRIBUTORS

- Ready to run, self-contained electronic breakerless design
- Easy access top mount fully adjustable and lockable stainless steel mechanical advance and nylon pads to insure long term smooth operation
- Adjustable vacuum advance, with lockout insert for mechanical advance only operation

YEAR	APPLICATION	PART#
All	Std. Deck Height Chevrolet 8 cylinder engines	52100
	except 348 & 409 engines	
1955-81	Pontiac 301, 326, 350, 389, 400, 421, 428 & 455	52102
	engines except 1973-74 Super Duty 455 engines	
1964-90	Oldsmobile 260, 307, 330, 350, 400, 403, 425	52103
	& 455 engines	
1958-76	Ford 332, 352, 360, 390, 410, 427 & 428 "FE" engines	52200
1962-80	Ford 221, 255, 260, 289, 302 & 302 Boss engines	52201
1968-95	Ford 351C, 351 Boss, 351M, 400, 429& 460 engines	52202
1969-80	Ford 351W engines	52204
1959-79	Chrysler/Dodge/Plymouth 413, 426, 440 "RB" & Hemi engines	52300
1965-1993	Chrysler/Dodge/Plymouth 273, 318 (1967 - later) 340 & 360	52301
	"LA" engines except Dodge "Magnum" 5.2L/5.9L engines	
1958-79	Chrysler/Dodge/Plymouth 350, 361, 383 & 400 "B" engines	52302
All	Holden 8 cylinder 253, 304 & 308 engines	52108



52100

For maximum performance, use ACCEL's 8145, 8145C, 8140HV, 140001 & 140008 coils.

Replacement caps and rotors in colors!

Tan	8348	Red	8348R
Blue	8348B	Black	8348K

HIGH PERFORMANCE DISTRIBUTORS FOR PRE-1954 FORDS

Features At A Glance:

- Available in Point, Unilite or Magnetic Breakerless styles
- Adjustable mechanical advance
- Self-lubricating bushings provide years of trouble-free service
- Includes Mallory Super-Duty Cap and Rotor with brass terminals
- Ready to use with a matching coil or can be used to trigger HYFIRE® Electronic Ignition Controls
- Available for most 4, 6, and 8 cylinder American engines - refer to the Mallory catalog or visit www.MalloryRacing.com for complete application information

YEAR	CYL	ENGINE	UNILITE** ELECTRONIC	UNILITE ** W/TACH DRIVE	MAGNETIC** BREAKERLESS	DUAL*** POINT
1949-53	V8/RH	All Flat Head	3727501	—	5027501	2527501
1942-48*	V8/RH	All 2 Bolt Flathead	3772001	5072001	—	2572001
1932-41	V8/RH	All 3 Bolt Flathead	3772101	5072101	—	2572101
Model A	L4/LH	All	4501105	—	—	2301105
Model B	L4/LH	All	4501106	—	—	2301106

* Certain 42-48 applications may encounter some water pump/fan interference due to slight increase in distributor length. Modifications may be required to install distributor.

** NOTE: Unilite® and Magnetic Breakerless Distributors require the ignition system to be converted to 12-volt negative ground.

*** 2301105 and 2301106 are single point distributors.



3772001



3772101



4248201



29219



29216

COMPS/S 42 SERIES DISTRIBUTORS

Street Rodders have relied on the Mallory 42 Series distributors for many years. Known for its dependable, bullet-proof electronics, the 42 Series distributors are all CNC machined from billet aluminum and are available in a wide variety of applications.

42 Series Distributors Features

- Ready to run, self-contained magnetic breakerless design
- Easy 3-wire hookup with quick-disconnect wire connector
- Simple to adjust mechanical and vacuum advance
- Includes Vacuum Advance Eliminator conversion plate
- Can be converted to a traditional style female cap
- Ball bearing upper & bushing lower for maximum stability and RPM
- Compatible with CD ignition systems
- 208 male style cap w/wire retainer - 20% more cross-fire resistant
- Adjustable flange on 4248211
- Machined for o-rings (Chevrolet Only)
- Steel Distributor Gear (Ex. Chrysler)

Mallory also makes a number of other performance distributor styles including Dual-Point, Unilite, HEI, TFI, and even Front Drive Remote-Mount distributors. For a complete product listing, refer to the Mallory catalog or visit www.malloryracing.com

ENG YEAR	CYL	ENGINE	42 SERIES W/STACK CAP
CHEVROLET - Includes All Distributor Equipped Engines Including Corporate GM Competition Engines			
1955-96	V8-RH	262-454, 502 except 1955-74 Corvette w/ mech tach, 348-409, Rocketblock, Tall Block, and Merlin/Superblock	4248201
1955-96	V8-RH	262-454, 502 except 1955-74 Corvette w/ mech tach, 348-409, Rocketblock, Tall Block, and Merlin/Superblock with adjustable collar	4248211
1955-74	V8-RH	262-454 1955-74 Corvette w/ mech tach, (except 348-409, Rocketblock, Tall Block, and Merlin/Superblock)	4264511
CHRYSLER			
1965-95	V8/RH	LA Engines 273, 318 (67-up), 340 and 360	4257911
1958-78	V8/LH	B Engines 350, 361, 383 and 400	4257711
1959-79	V8/LH	RB Engines 413, 426 Wedge and 440	4257811
1966-71	V8/LH	426 Hemi	4257811
FORD MOTOR COMPANY			
1968-95	V8/LH	351C/M, 400, 429 and 460	4256711
1958-76	V8/LH	332, 352, 360, 390, 406, 410, 427, and 428	4255311
1969-95	V8/LH	351W	4255411
1962-95	V8/LH	221, 255, 260, 289, 302	4255111
OLDSMOBILE			
1964-82	V8/HL	Olds Eng. 330, 350, 400, 403, 425 and 455	4263411
1980-89	V8/HL	Olds Eng. 260, 307	4263411
PONTIAC			
1963-81	V8/LH	Pont Eng. 265, 301, 326, 350, 389, 400, 421, 428 and 455	4258011

UNIVERSAL CHROME IGNITION COILS

- 12-volt coil features an oil-filled design and arc resistant alkylid top for superior performance, insulation and cooling.
- Ideal for street and performance applications
- Fits most original equipment coil brackets

The **29219** coil eliminates the need for a separate ballast resistor. This coil is specifically designed to deliver optimum performance when used with:

- Mallory UNILITE® or Magnetic Breakerless Ignitions
- Mallory E-Spark Conversion Kits
- Mallory Electronic Ignition Conversion Kits

NOT for use with Mallory HYFIRE® Electronic Ignition Control or any other high energy, inductive storage or capacitive discharge ignition system

The **29216** coil is designed to be used with a separate ballast resistor. It delivers optimum performance when used with:

- Mallory UNILITE® or Magnetic Breakerless Distributors equipped WITH a capacitive discharge ignition
- Mallory HYFIRE® IV and VI Series Electronic Ignition Controls
- Original equipment breakerless electronic ignition systems

NOT for use with Mallory HYFIRE® Electronic Ignition Control P/N 629, 630, 693, 29026, 29062A, 29028, 29029, 29037, or any other high energy, inductive storage ignition system

AFTERBURNER™ SWITCHABLE COIL

In the normal mode, the coil is designed to boost low RPM performance by maximizing current output to produce longer arch duration times to improved burn efficiency, resulting in enhanced throttle response, improved economy and reduced emissions. In the switched or high RPM mode, the coil is designed to boost higher RPM performance by producing higher voltage levels to better fire the mixture under high cylinder pressures conditions, such as when running nitrous or under boost. The innovative remote switch location kit makes it easy and convenient to switch the ACCEL Afterburner™ coil from one mode to the other, while inside the vehicle. Works with either with the stock vehicles inductive ignition system or with an aftermarket CD ignition system.

Afterburner™ Switchable Coil140025



140025

PROMASTER® e CORE SERIES IGNITION COILS

For street-driven vehicles with breaker point ignition or OE electronic ignition. Delivers optimum performance when used with these Mallory ignition products: UNILITE® Distributor with a HYFIRE® Capacitive Discharge Ignition; Magnetic Breakerless Distributor with a HYFIRE® Capacitive Discharge Ignition or Dual Point Distributor. Primary Resistance 0.5 ohms, Secondary Resistance 8.9K ohms, Maximum Voltage 51,000 volts, Inductance 5.6 mH, Turns Ratio 99:1, Peak Current 260 mA, Spark Duration 250 uS. Effective to 6500 RPM when used with a point type distributor and effective to 8000 RPM when used with a Mallory HYFIRE® Electronic Ignition Control.

Universal ProMaster eCore coil

Black 30440

Red 30441



30440

30441

HYFIRE® DIGITAL CD IGNITION SYSTEMS

High output multi-spark ignition system provides quicker acceleration and improved throttle response. Available with or without an easy-to-adjust digital rev limiter – 4,500 to 12,000 RPM – and no chips required! Features the latest microprocessor-controlled circuitry. Small lightweight aluminum housing is easy to install and provides maximum heat transfer for improved dependability. Works with points, OEM or aftermarket electronic ignition, or magnetic crank triggers except Hall effect.

HYFIRE 6-A® Digital CD Ignition without Rev Limiting6852M

HYFIRE® 6-AL Digital CD Ignition with Rev Limiting6853M



6852M

6853M

E-SPARK® CONVERSION KITS

These low cost conversion kits eliminate points in GM, Ford and Chrysler distributors. Designed with ease of installation in mind, these kits eliminate the pesky problem of constantly having to change and adjust points forever. Even better, everything fits inside the distributor so everything is self-contained and looks original on the outside. Provides better drivability and improved throttle response No moving parts to wear out and easy to install.

YEAR	APPLICATION	PART#
57-74	GM Delco, all V-8 engines w/externally adjustable points (window cap style)	.61001M
57-74	Ford Motorcraft, all V-8 engines w/single point distributors	.61002M
61-73	Chrysler, all V-8 engines w/single point distributors	.61003M
	Individual E-Spark replacement module	.6100M



61001M



IGNITION SYSTEMS & ACCESSORIES

“Shorty”



ACCEL'S RACE PROVEN U-GROOVE SHORTY SPARK PLUGS

Designed for use where spark plug clearance is a problem, these spark plugs are a full 1/4” shorter than ordinary plugs and eliminates burning the spark plug boot or dimpling the header tube. The patented U-Groove design produces a larger spark nucleus that stimulates faster combustion. The end result is an increase in performance with improved throttle response, greater fuel efficiency and reduced emissions. For complete application information, refer to the ACCEL catalog or www.ACCEL-Ignition.com.

- Replaces Champion RC12, RC13 & RC14 Heat Ranges0416S
- Replaces Champion RC8, RC9, RC10 Heat Ranges0414S
- Replaces AC/DELCO R42TS, R43TS Heat Ranges0574S
- Replaces AC/DELCO R44TS, R45TS Heat Ranges0576S
- Replaces AC/DELCO R44S, R45S Heat Ranges0437S



UNIVERSAL SPARK PLUG WIRE DIVIDER BRACKET SET

Brackets are complete with competition wire separators which fit 7 or 8mm wires keeping them sufficiently insulated and separated from each other to minimize “cross-firing.” Adjustable tabs allow for easy mounting onto most valve covers. Made from aluminum and available in three attractive colors, they measure 14-3/4” long and are packaged two per set.

- Brushed Aluminum6018
- Blue Anodized6022
- Red Anodized6023



SPARK PLUG WIRE DIVIDER BRACKETS FOR CHEVYS

Designed to fit late model small block Chevy's 87-96 with center hold down valve covers, these aluminum wire divider brackets come complete with wire separators which fit 7 or 8mm wires, keeping them insulated and separated from each other to minimize crossfire. Brackets are brush finished and are packaged two per set.

- Brushed Aluminum Late Small Block6042

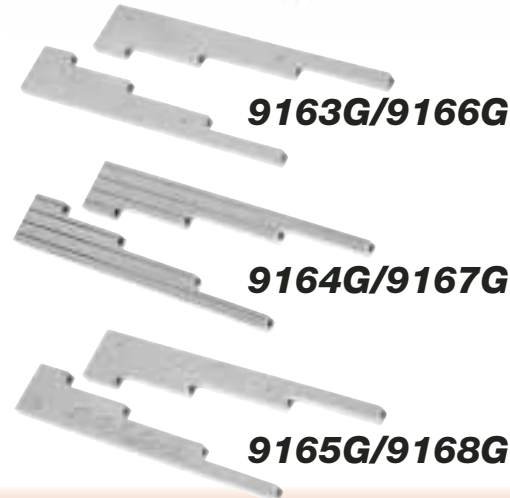

SPARK PLUG WIRE LOOM KITS

These wire loom kits preserve the life of spark plug wires. Made from die cast aluminum and polished to a high luster, these wire loom kits give an engine a show winning edge. Available in plain, ball milled and flamed for most V-8's or Chevrolet, 305, 350 1987-96 engines w/center bolt valve covers.

- Universal Wire Loom Set – Plain9163G
- Universal Wire Loom Set - Ball Milled9164G
- Universal Wire Loom Set – Flamed9165G
- SBC Center Bolt Wire Loom Kit – Plain9166G
- SBC Center Bolt Wire Loom Set - Ball Milled9167G
- SBC Center Bolt Wire Loom Set – Flamed9168G



CLASSIC T-STYLE FUEL BLOCKS

These are precision die-cast, chrome-plated blocks, ideal for plumbing tri-power set-ups, dual inlet Holley's with nitrous or any combination requiring multiple fuel distribution. Minimum flow restriction is assured with a 3/8" diameter NPT tapped inlet and 1/4" diameter NPT tapped outlets. Four corner holes and screws are provided for easy installation.

Dual outlet (2)6150
Triple outlet (3)6151
Quad outlet (4)6152

6151



CHROME-PLATED HIGH PERFORMANCE FUEL FILTER

Features a replaceable, powdered bronze element for positive filtration, while keeping restriction to a minimum. The unit has 3/8" O.D. inlet/outlet and includes two line clamps for easy installation. Individually packaged. NOT FOR FUEL INJECTION SYSTEMS.

Chrome-plated fuel filter6153
Replacement bronze element6154

6153



BILLET FUEL FILTERS

Machined from T6061-T6 billet aluminum alloy, these fuel filters incorporate a 304 stainless steel plated filter disc rated at 10 microns and flows over 15 GPM or 800 GPH. These fuel filters can be used on low-pressure carburetor or high-pressure fuel injected applications. Available in barbed or AN fitting ends.

Billet Fuel Filter 3/8" Barbed Ends6161G
Billet Fuel Filter - 6 AN Ends6162G
Billet Fuel Filter - 8 AN Ends6163G
Replacement Fuel Filter Disc6165G

6162G



MICRO ELECTRIC FUEL PUMPS

- Compatible with all automotive fuels and additives
- Solid-state worry free electronics
- Eliminates vapor lock and flooding
- 12 Volt negative ground systems only

Universal design for most domestic 4, 6, & 8 cylinder carburetor applications. Delivers 4-7 PSI

Universal design for most import 4, 6 cylinder carburetor applications. Delivers 2-3.5 PSI

NOT FOR FUEL INJECTION APPLICATIONS.





4140



4307M

FUEL PUMPS & REGULATOR

Mechanical or electrical, Mallory has a complete line of street and race fuel pumps. For complete application information, refer to the Mallory catalog.

Model 70 High Performance Electric Fuel Pump	4070M
Model 110 High Performance Electric Fuel Pump	4110
Model 140 High Performance Electric Fuel Pump	4150
Adjustable Fuel Pressure Regulator	4307M



29723



29724

1-1/2" Diameter Fuel Pressure Gauges

These high quality pressure gauges can be mounted directly into any 1/8" NPT threaded pressure port for a quick easy reference. Liquid filled for improved needle stability high vibration applications. 270+ degree sweep needle makes for quicker pressure checks.

0-15 PSI Range - liquid filled	29724
0-30 PSI Range - liquid filled	29723

SHADOW SERIES AN FITTINGS

Mr. Gasket's Shadow Series is the hottest new look in AN fittings. Each fitting is exactly constructed from aluminum with a unique black and silver appearance. These fittings are available in both push on and cutter style fittings to suit nearly any plumbing project.

CUTTER TYPE SWIVEL FITTINGS FOR USE WITH STAINLESS STEEL BRAIDED HOSE:

When maximum performance and durability is required, Mr. Gasket swivel fittings deliver. These fittings are good up to 1000 PSI and are compatible with virtually all automotive chemicals.

STYLE	SIZE	PART NO.
 Straight Swivel	-4 AN	S4
	-6 AN	S6
	-8 AN	S8
	-10 AN	S10
	-12 AN	S12
 45° Swivel fitting	-4 AN	F454
	-6 AN	F456
	-8 AN	F458
	-10 AN	F4510
	-12 AN	F4512
 90° Swivel fitting	-4 AN	F904
	-6 AN	F906
	-8 AN	F908
	-10 AN	F9010
	-12 AN	F9012

STYLE	SIZE	PART NO.
 120° Swivel fitting	-4 AN	F1204
	-6 AN	F1206
	-8 AN	F1208
	-10 AN	F12010
	-12 AN	F12012
 150° Swivel fitting	-4 AN	F1504
	-6 AN	F1506
	-8 AN	F1508
	-10 AN	F15010
	-12 AN	F15012
 180° Swivel fitting	-4 AN	F1804
	-6 AN	F1806
	-8 AN	F1808
	-10 AN	F18010
	-12 AN	F18012

FUEL SYSTEM COMPONENTS



STAINLESS STEEL BRAIDED HOSE	4 FEET	PART #	10 FEET	PART #	25 FEET	PART #
	-4 AN	S44	-4 AN	S104	-4 AN	S254
	-6 AN	S46	-6 AN	S106	-6 AN	S256
	-8 AN	S48	-8 AN	S108	-8 AN	S258
	-10 AN	S410	-10 AN	S1010	-10 AN	S2510
	-12 AN	S412	-12 AN	S1012	-12 AN	S2512

PUSH ON TYPE FITTINGS FOR USE WITH RUBBER PUSH-ON HOSE:

These fittings are a great alternative to the stainless cutter type fitting. They're lighter weight, and easier to assemble, yet still good to 250 PSI.

STYLE	SIZE	PART NO.	STYLE	SIZE	PART NO.
Straight Push-on 	-4 AN	P4	120° Push On fitting 	-4 AN	P1204
	-6 AN	P6		-6 AN	P1206
	-8 AN	P8		-8 AN	P1208
	-10 AN	P10		-10 AN	P12010
	-12 AN	P12		-12 AN	P12012
45° Push On fitting 	-4 AN	P454	150° Push On fitting 	-4 AN	P1504
	-6 AN	P456		-6 AN	P1506
	-8 AN	P458		-8 AN	P1508
	-10 AN	P4510		-10 AN	P15010
	-12 AN	P4512		-12 AN	P15012
90° Push On fitting 	-4 AN	P904	180° Push On fitting 	-4 AN	P1804
	-6 AN	P906		-6 AN	P1806
	-8 AN	P908		-8 AN	P1808
	-10 AN	P9010		-10 AN	P18010
	-12 AN	P9012		-12 AN	P18012

PUSH ON RUBBER HOSE	4 FEET	PART #	10 FEET	PART #	25 FEET	PART #
	-4 AN	R44	-4 AN	R104	-4 AN	R254
	-6 AN	R46	-6 AN	R106	-6 AN	R256
	-8 AN	R48	-8 AN	R108	-8 AN	R258
	-10 AN	R410	-10 AN	R1010	-10 AN	R2510
	-12 AN	R412	-12 AN	R1012	-12 AN	R2512



Shadow Series

PIPE THREAD ADAPTORS

When your plumbing job requires a conversion from NPT threads to AN style fittings, these adaptors have you covered. All adaptors are anodized black.



PIPE THREAD SIZE	AN SIZE	PART #
1/8"	-6	A186
1/4"	-6	A146
3/8"	-6	A386
3/8"	-8	A388
3/8"	-10	A3810
1/2"	-8	A128
1/2"	-12	A1212
3/4"	-12	A3412

WELD-IN BUNGS

These aluminum bungs are not anodized for optimal weld adhesion. They also include a centering ring to make welding them in a snap.



SIZE	PART #
-4 AN	W4
-6 AN	W6
-8 AN	W8
-10 AN	W10
-12 AN	W12
-16 AN	W16
-20 AN	W20



HOSE FINISHERS

The Shadow series hose finishers come in both our unique black and titanium anodized colors, as well as a clear anodized finish. These finishers can be used in conjunction with our push on fittings for the swivel look, or anywhere else you'd use a hose clamp.

SIZE	COLOR	PART #
-4 (1/4" ID)	Titanium	E41
	Clear	E42
	Black	E43
-6 (3/8" ID)	Titanium	E61
	Clear	E62
	Black	E63
-8 (1/2" ID)	Titanium	E81
	Clear	E82
	Black	E83
-10 (5/8" ID)	Titanium	E101
	Clear	E102
	Black	E103

SIZE	COLOR	PART #
-12 (3/4" ID)	Titanium	E121
	Clear	E122
	Black	E123
-24 (1 1/2" ID)	Titanium	E241
	Clear	E242
	Black	E243
-32 (2" ID)	Titanium	E321
	Clear	E322
	Black	E323

SHIFTERS & ACCESSORIES



STREET ROD SHIFTER

This shifter is designed and quality-built by Hurst, "America's Number One Shifter Company". Considering Hurst's reputation for reliability, it's no wonder why street rodders worldwide choose the Street Rod Shifter for their vehicles!

- Positive detent activation
- Built-in neutral/park start safety switch
- Rear mount shifter features a machined billet aluminum handle with an attractive 1/2-20 thread billet knob for that hi-tech look
- Forward mount shifter utilizes a chrome-plated bent stick and black 5/16-18 thread knob for the car that has a "Resto" look
- All shifters come complete with mounting brackets, linkage rod, installation hardware and detailed instruction sheet

Transmission	Forward Mount w/Chrome Resto-Style Stick	Rear Mount w/ Aluminum Handle
TH 200/350/400	3835690	3835680
TH 700R4	3835691	3835681

3835691

3835681



CLASSIC SHIFTER KNOBS

The original Hurst Classic design consists of a solid high gloss, high strength plastic with an engraved inlaid shift pattern. Most knobs are 1-3/4" diameter (excluding as noted below) with a molded-in brass thread insert. All knobs include jam nut.

THREAD SIZE	4 SPEED		5 SPEED		6 SPEED	
	White	Black	White	Black	White	Black
3/8-16	163 0003	163 0103	163 0008	163 0108	163 0040	163 0140
3/8-24	163 0002	163 0102	—	—	—	—
7/16-20	163 0022	—	163 0004	163 0104	—	—
9/16-18 Corvette C4	—	—	—	—	*163 0055	*163 0155
9/16-18 Corvette C5	—	—	—	—	*163 0056	*163 0156
12mm x 1.75 Mustang	—	—	*163 0014	*163 0114	*163 0060	*163 0160
16mm x 1.50 Camaro/FB	—	—	—	—	*163 0016	*163 0116

* 2.25" Diameter

1630008



1630108

SKULL SHIFTER KNOB

This skull shifter knob is sure to draw attention to any interior. Crafted from solid, heavyweight metal, it is beautifully polished and chrome-plated for long-lasting style, and will fit 5/16" to 1/2" diameter shifter sticks. Complete with adapters, set-screw, and hex key for a fast, easy installation.

Skull Shifter Knob9628

9628



CHROME-PLATED SHIFTER BALL

Originally designed as a replacement ball for the 1960's Muncie shifter, this 1-5/8" diameter chrome-plated shifter ball is sure to add a nostalgic touch to your car. Made from solid, heavyweight metal and universal in design, this shifter ball will fit all 5/16" to 1/2" diameter shifter sticks. Complete with adapters, setscrew and hex key for fast, easy installation.

Chrome-Plated Shifter Ball9627

9627



PISTON STYLE GEAR SHIFT KNOB

This chrome-plated beauty is perfect for street rods or for any vehicle that needs that certain custom touch. Universal design fits 5/16" through 1/2" shifter sticks.

Piston Style Gear Shift Knob9625

9625





ACCESSORIES & INTERIOR PRODUCTS



1361000

HURST EQUIPPED EMBLEM

Based on original HURST blueprints, this HURST EQUIPPED emblem is an authentic reproduction of the one used on the late '60's muscle cars equipped with a factory Hurst shifter. Made of durable ABS plastic with 3M adhesive tape backing for permanent mounting. Nominal size is 1-1/4" high by 5 -1/4" long. Individually packaged.

Hurst Equipped emblem1361000

5656



CHROME-PLATED THROTTLE PEDAL ASSEMBLY

This attractive chrome-plated throttle pedal assembly is ideal for any street rod application and features a full 360 degree splined rotation adjustment arm with three linkage holes for cable attachment. Mounting is made easy by bolting direct to the firewall. The pedal pivots on a nylon bushing for quiet, efficient operation and long life.

Chrome Plated Throttle Pedal Assembly5656

9110G

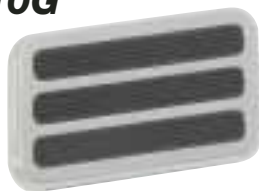

ALUMINUM PEDAL PADS

Made from polished aluminum, these pedals have rubber inserts for a positive grip.

Brake Pedal For Automatic Cars9110G

Gas Pedal For Automatic Cars9111G

9111G



9645

BAREFOOT PEDAL PADS

No street rod is complete without one of these! Universal design simply clamps over the original pedal for permanent, non-slip installation.

Gas Pedal, Universal9645

Dimmer Switch Pedal9644

9644



BLUE DOTS

Universal in design, these blue dots fit most taillights to give them a unique "purple glow". The chrome-plated bezel has four retaining tabs for positive attachment and only a 15/16" hole is required for installation. This product is intended for off-road use only and may not be legal for street use in some states. Packaged 2 per set.

Plastic Blue Dots5100
Glass Blue Dots5101



5100

HEADLIGHT HALF SHIELDS

These great looking triple chrome-plated headlight half shields give any vehicle that customized appearance of the 50's or the muscle car look of the 60's. Available in four sizes and fit most round or rectangular headlights. Packaged 2 per set.

Small Round 5 3/4" diameter9650
Large Round 7 1/2" diameter9651
Small Rectangular 4" x 6"9652
Large Rectangular 6" x 8"9653



9650

9652

LICENSE PLATE FRAMES

These chrome-plated die-cast license plate frames will keep your plates protected and looking good. Available in 3 styles: plain, with a built-in 12V light or with a skull and cross-bones design.

Plain frame9100G
Frame with light9101G
Frame with Skull and Cross-bones9102G
License plate bolt kit, chrome-plated, 2/set9543

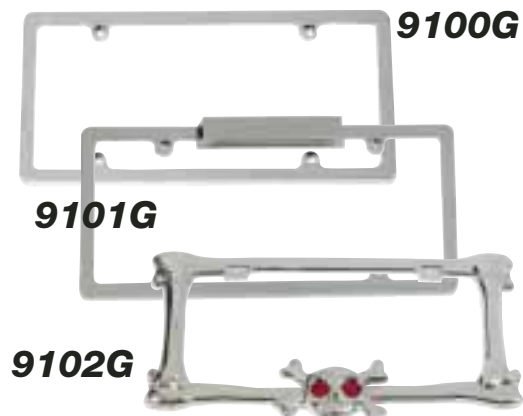

9100G

9101G

9102G

5102



FLUSH MOUNT TIRE VALVES

This advanced design tire valve will give any custom wheel a clean, smooth appearance by eliminating unsightly valve stems. Manufactured from the highest quality brass and beautifully chrome plated, these flush mount tire valves are engineered to fit all tubeless applications on most chrome, steel, or aluminum wheels. Fits .453" valve stem hole and includes special inflator adapter.

Flush Mount Tire Valves, 4/set5102

3663



HEX CHROME VALVE STEM CAPS

Replaces stock plastic caps or stolen custom covers.

Hex Chrome Valve Stem Caps, 4/Set3663

5104



CHROME WHEEL PLUGS

These Chrome Wheel Plugs are made to cover the unused boltholes on dual bolt pattern wheels, such as Cragar's Supertrick II, Superslot II and most others. They are easy to install as they simply snap into all standard 11/16" diameter lug nut holes. Packaged five per set.

Chrome Wheel Plugs5104

5424



EXHAUST CUTOUTS

Manually control the flow of your vehicle's exhaust either through the stock exhaust system or straight out the pipe with an exhaust cutout! Made from durable cast iron, the exhaust cutout will accept 2" OD exhaust pipes, though it can be used on other size tubing with the use of adapters/reducers (Not included). Brazing is required. Each cutout is complete with a control cable and installation instructions.

Exhaust Cutout5424

NOSTALGIA HURST T-SHIRT

Constructed from premium quality 100% pre-shrunk cotton and printed in vivid, fade-resistant colors, these quality-made tee's have a bold racing stripe with logo on the front and a large nostalgia Hurst logo on the back.

SIZE	PART NO.	SIZE	PART NO.
Small	74109G	X-Large	74112G
Medium	74110G	2X-Large	74113G
Large	74111G	3X-Large	74114G



NOSTALGIA HURST CAP

Relive the era of 1965 when the spectator stands at the U.S. Nationals in Indianapolis was a sea of yellow as everyone at the raceway was given one of these caps to promote Hurst Shifters. Made of premium quality materials and construction, this bright yellow cap features a black edge bill with large nostalgia Hurst logo and Velcro strap for easy adjustment.

Nostalgia Hurst hat74108G

74108G



NOSTALGIA DECALS

These nostalgic Hurst, Hays and Mr. Gasket decals are real collector items and have been authentically reproduced from the past when these companies were just getting started in the high performance industry. Silk screened on vinyl and die cut for easy removal with self adhesive back for use on any clean dry surface.

Nostalgia decal set1320010



1320010

HURST COLLECTABLE CAR

HURST celebrates its 45th Anniversary with a flamed out '32 Ford Sedan Delivery Open Wheel Street Rod. This is a 1/25th scale collectable model manufactured by SpecCast. There have only been 3,500 produced.

HURST Collectable Car73970G





73830G

MR. GASKET PERFORMANCE GROUP APRON

Perfect for keeping you clean while working on your car, or at your backyard grill! This full-length adjustable apron is made from a 65% cotton/35% polyester blend, and features two pockets and adjustable straps.

Mr. Gasket Performance Group Apron73830G



FLAME T-SHIRT

These new tees are on fire! Featuring the Mr. Gasket Performance Group flamed logo, as well as all of our brand logos, these 100% cotton T-shirts will make you a hot item! Available in white and oatmeal.

WHITE	PART NO.	OATMEAL	PART NO.
Small	73601G	Small	73607G
Medium	73602G	Medium	73608G
Large	73603G	Large	73609G
XLarge	73604G	XLarge	73610G
2XLarge	73605G	2XLarge	73611G
3XLarge	73606G	3XLarge	73612G

73829G



MR. GASKET CAMOUFLAGE CAP

Here's a great way for muscle car drivers to express their opinion about sport compacts. With the words "Gone Import Hunting!" on the front, no one will doubt where your loyalties lie. 60% cotton 40% polyester construction, this cap features a three and 1/2 inch crown, a plastic adjustable strap enclosure, and brown sewn eyelets.

Mr. Gasket Camouflage Cap73829G



73828G

STRAW HAT

Savor the shade on the golf course, fishing or just plain relaxing! This hat has a four inch crown with flat top, and its elasticized cotton sweatband fits all sizes. Included are three different interchangeable bands, black Mr. Gasket Racing, red Mallory Racing, yellow ACCEL racing.

Straw Hat73828G



EMBROIDERED, SEWN-ON PATCHES

HURST	SIZE: 1-7/8" H X 2-14" W	73923G
HAYS	SIZE: 1-3/8" H X 2-3/16" W	73924G
LAKEWOOD	SIZE: 1-1/2" H X 1-5/8" W	73925G
MR. GASKET	SIZE: 1" H X 4-1/8" W	73926G
ACCEL	SIZE: 1-1/8" H X 2-7/8" W	73927G
MALLORY	SIZE: 1-3/8" H X 2-7/8" W	73928G

MR. GASKET PERFORMANCE GROUP

The Mr. Gasket Performance Group consists of eight premier brands. Be sure to specify the brand names listed below to insure quality, reliability and value for all of your performance and custom needs.



ACCEL offers a wide range of performance ignition products including digital fuel injection systems, fuel injectors, coils, distributors, caps, rotors, ignition wires and spark plugs.

Erson manufactures a complete line of camshafts and valve train components ranging from street to strip applications, including FSP valve springs, push rods and roller rocker arms.

Hays builds a wide range of high performance clutches for street and strip applications including pressure plates, discs, flywheels and complete clutch kits. Hays also has a complete line of custom-built specialty clutches for drag racing and tractor-pulling applications.

Hurst is the leading manufacturer of racing shifters for both manual and automatic transmission applications. Hurst also has a wide range of shifter accessories including the Original Roll/Control.

Jacobs Electronics manufactures high tech electronics for street, strip and off road use including ignition coils, ignition amplifiers, spark plug wires and nitrous controls.

Lakewood manufactures safety and suspension products including hydroformed bellhousings, traction bars, drag shocks and lowering springs.

Mallory manufactures a complete line of high performance racing ignition and fuel systems, including ignition boxes, distributors, magnetos, ignition wires, caps, rotors, fuel pumps and regulators.

Mr. Gasket has an extensive line of high performance parts and accessories including gaskets, fasteners, chrome plated accessories, engine components, carburetor adapters and spacers, cooling system products, suspension components and fuel system accessories.

LOCAL DEALER **1-888-MRGASKET**

To find your local dealer, call 1-888-MRGASKET, visit our web site at www.mrgasket.com or look in the Yellow Pages under Automobile Performance, Racing & Sports Car Equipment.

INTERNET **www.mrgasket.com**

Mr. Gasket has an extensive internet presence which includes new, downloadable catalogs, new product listings, frequently asked questions, tech tips, and installation instructions.



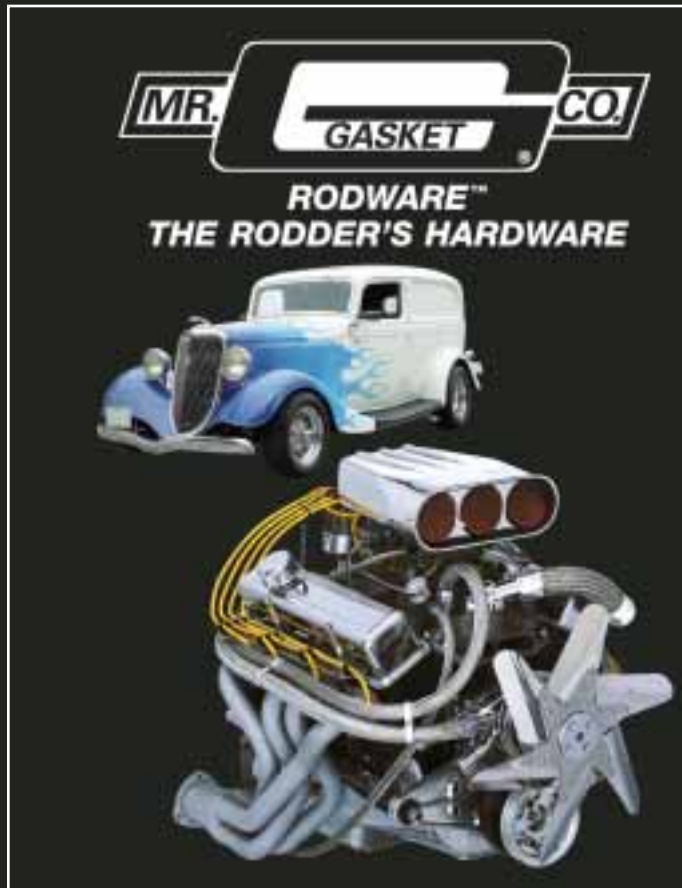

The Mr. Gasket Performance Group
Cleveland, Ohio
www.mrgasket.com

©2005 Printed in USA

74153G

